

ANCHO NOMINAL 140

Series IBY a IFY

	IBY	ICY	IDY	IEY	IFY
	mm	mm	mm	mm	mm
A	139	140	141	142	144
B	86	86	86	86	86
D	DE + 23	DE + 24	DE + 25	DE + 26	DE + 28
E ¹	10	10	10	10	10
E ²	35	35	35	35	35

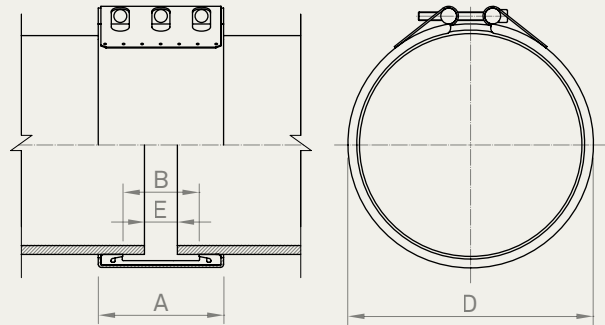

	Calidad W1		Calidad W2		Calidad W4		Calidad W5	
	AISI	DIN	AISI	DIN	AISI	DIN	AISI	DIN
Carcasa			304 L	1.4307	304 L	1.4307	316 L	1.4404
Tornillos			1035	1.0501	304	1.4301	316	1.4401
Ejes			1045	1.0503	304 L	1.4307	316 L	1.4404
Acero interior (cierre)			304 L	1.4307	304 L	1.4307	316 L	1.4404

Manguito de estanqueidad: EPDM / NBR / Silicona

DN	IBY			ICY			IDY			IEY			IFY		
	PT bar	Dia	Par Nm	PT bar	Dia	Par Nm	PT bar	Dia	Par Nm	PT bar	Dia	Par Nm	PT bar	Dia	Par Nm
150	23	M 10	20	30	M 10	20									
200	18	M 10	20	24	M 10	20	30	M 10	20						
250	15	M 10	20	19	M 10	20	24	M 10	20						
300	12	M 10	25	16	M 10	20	20	M 10	20						
350	11	M 10	30	14	M 10	20	18	M 10	20	21	M 10	20	28	M 12	25
400	9	M 10	30	13	M 10	20	16	M 10	20	19	M 10	20	25	M 12	25
450	8	M 10	25	11	M 10	25	14	M 10	25	17	M 12	30	22	M 12	30
500	8	M 10	30	10	M 10	25	13	M 10	25	15	M 12	30	20	M 12	35
550	7	M 10	30	9	M 10	30				14	M 12	35	19	M 12	35
600	6	M 10	30	9	M 10	30				13	M 12	35	17	M 12	35
650	6	M 10	35	8	M 10	35				12	M 12	45	16	M 12	45
700	6	M 10	35	7	M 10	35				11	M 12	45	15	M 12	45
750	5	M 10	40	7	M 10	40				10	M 12	45	14	M 16	60
800	5	M 10	40	6	M 12	50				10	M 12	50	13	M 16	70
850				6	M 12	60				9	M 12	60	12	M 16	70
900				6	M 12	60				9	M 12	60	12	M 16	80
950				5	M 12	60				8	M 12	60	11	M 16	80
1000				5	M 12	70				8	M 12	70	10	M 16	90
1100				5	M 12	70				7	M 16	90	9	M 16	90
1200				4	M 12	80				7	M 16	100	9	M 16	100

Diámetro nominal orientativo para comprobar la escala de presión. Fabricación de todas las medidas dentro del rango DN.

E¹ separación admisible sin banda interior E² separación admisible con banda interior PT presión de trabajo DN diámetro nominal DE diámetro exterior

DE	Máxima diferencia de diámetros	Máxima desviación angular	Máxima desalineación
mm	mm	grados	mm
150 - 250	2,5	2,0	2,0
250 - 500	2,5	2,0	3,0
500 - 1200	3,0	2,0	3,0

Véase página 5 (Tolerancias admisibles)

Para el correcto funcionamiento de las uniones, deben respetarse las instrucciones de montaje.

Presión de prueba = 1,5 x PT