

PARA TUBOS DE POLIETILENO Y PVC

Serie FIX-U

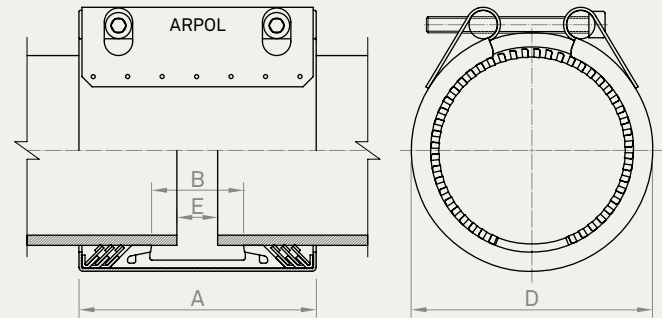

En los tubos de PVC y PE es necesario colocar un anillo interior, para evitar la deformación y la reducción del diámetro debido al diferencial de temperatura.

	Calidad W1		Calidad W2		Calidad W4		Calidad W5	
	AISI	DIN	AISI	DIN	AISI	DIN	AISI	DIN
Carcasa					304 L	1.4307	316 L	1.4404
Tornillos					304	1.4301	316	1.4401
Ejes					304 L	1.4307	316 L	1.4404
Acero interior (cierre)					304 L	1.4307	316 L	1.4404
Anillos anclaje					302	1.4310	316 L	1.4404

Manguito de estanqueidad: EPDM / NBR / Silicona azul

DE	Rango	Presión		ΔT max.			Fuerza axial max.			Dimensiones				Tornillos		
		PT bar		°C			kN			A mm	B mm	D mm	E mm	Dia	Par Nm	
mm	mm			PT6	PT10	PT16	PT6	PT10	PT16							
63	62,0 - 64,0	10	16		40	30		7,5	9,5	99	31	85	5	M8	10	
75	74,0 - 76,0	10	16		40	30		10,6	13,5	117	31	97	5	M8	10	
90	89,0 - 91,0	10	16		40	30		15,2	19,4	117	31	112	5	M8	15	
110	108,0 - 111,0	10	16		40	30		22,7	29,0	117	45	132	5	M10	15	
125	123,0 - 126,0	10	16		40	30		29,4	37,5	118	45	149	5	M10	15	
140	138,0 - 142,0	10	16		40	30		36,9	47,0	118	45	164	5	M10	15	
160	158,0 - 162,0	10	16		40	30		48,1	61,4	118	45	184	5	M10	15	
180	178,0 - 182,0	6	10	16	40	20	15	40,6	43,3	51,5	201	95	217	10	M12	30
200	198,0 - 203,0	6	10	16	40	20	15	50,2	53,4	63,6	201	95	237	10	M12	30
225	222,0 - 227,0	6	10	16	40	20	15	63,5	67,6	80,4	201	95	262	10	M12	30
250	247,0 - 253,0	6	10	16	40	20	15	78,4	83,4	99,3	201	95	287	10	M12	40
280	277,0 - 283,0	6	10	16	40	20	15	98,4	104,7	124,6	201	95	317	10	M12	40
315	311,0 - 317,0	6	10		40	20		124,5	132,5		201	95	352	10	M12	40
355	351,0 - 357,0	6	10		40	20		158,1	168,3		201	95	392	10	M16	50
400	396,0 - 402,0	6	10		40	15		200,8	192,0		201	95	437	10	M16	50

E separación admisible PT presión de trabajo DE diámetro exterior ΔT diferencial de la temperatura mínima y máxima de la tubería

DE	Máxima diferencia de diámetros	Máxima desviación angular	Máxima desalineación
mm	mm	grados	mm
63	1,0	4,0	1,0
75 - 90	1,5	4,0	1,0
110 - 140	2,5	4,0	1,0
160 - 225	2,5	2,0	2,0
250 - 400	2,5	2,0	3,0

Véase página 5 (Tolerancias admisibles)

Para el correcto funcionamiento de las uniones, deben respetarse las instrucciones de montaje.

Presión de prueba = 1,25 x PT